

Product **DFM3550W500GC**

Specification

Center Frequency[fo]	3550MHz
Bandwidth[BW]	± 250.0MHz
Insertion Loss in BW	2.2 dB max.
Ripple in BW	1.5 dB max.
VSWR in BW	1.5:1max.
Attenuation [Absolute Value]	50.0 min. @ 0~2700 MHz 35.0 min. @ 2700~3195 MHz 30.0 min. @ 3905~5925 MHz 22.0 min. @ 5925~17000 MHz
In/Out Impedance	50Ω
Input Power	3 w max.
Operation Temperature	-40°C ~ +85 °C

Dimension (mm)

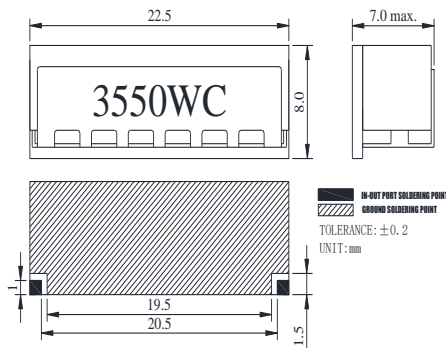

TEST GRAPH

